

PRINT MAY BE REDUCED - DO NOT SCALE.

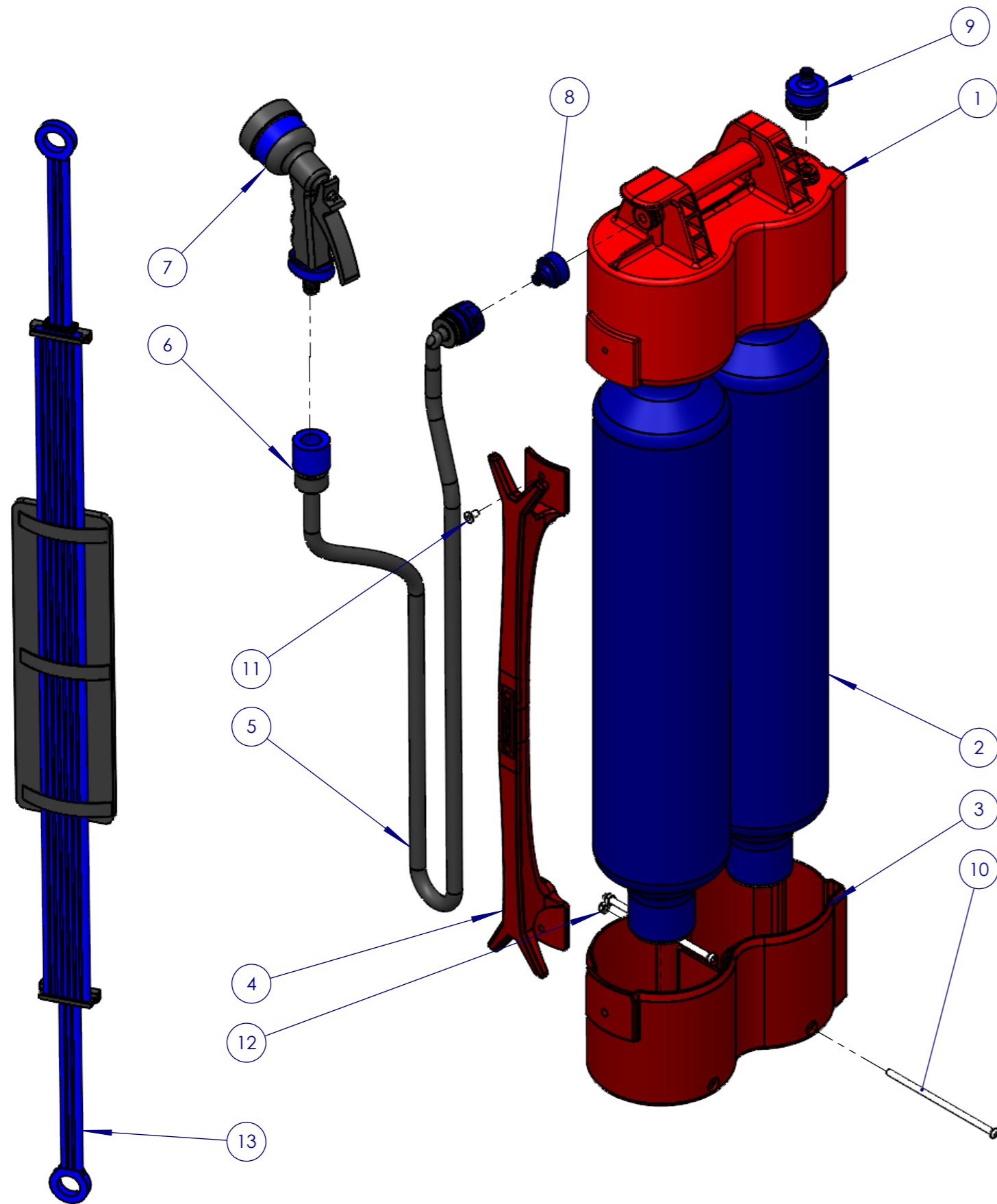

ITEM NO.	PART NO.	PART NAME	QTY
1	H2G-02	TOP LID	1
2	H2G-01	CANNISTER ASSEMBLY	2
3	H2G-03	BOTTOM LID	1
4	H2G-04	HANDLE	1
5	H2G-05	HOSE WITH SCREW AND QC FITTING	1
6	H2G-06	QUICK CONNECT WITH STOP	1
7	H2G-09	SPRAY GUN	1
8	H2G-07	SCREW ON QC FOR TOP LID (BLUE, <BATCH 0417-2000)	1
	H2G-07-01	SCREW ON QC FOR TOP LID (BLACK, >=BATCH 0417-2000)	1
9	H2G-08	1/2"-3/4"-1" TAP ADAPTER	1
10	MAK-UP-500	M6x140 BHSC Z/P	2
11	MAK-UP-502	M6x12 CSK SOCKET SCREW Z/P	2
12	MAK-UP-503	M6 NYLOC NUT	2
13	H2G-SA	HOSE2GO STRAP ATTACHMENT (UNITS FROM BATCH 1021-1000 INCLUDES THIS)	1



Sydney (Head Office) Ph: 1300 795 953
 15 Waltham St Fax: (02) 9439 9815
 Artarmon, 2064 www.makinex.com.au
 NSW, Australia sales@makinex.com.au

COPYRIGHT 2015 MAKINEX.
 WARNING: Copyright in this drawing remains the property of MAKINEX and copying in whole or part is not permitted without the written authority of the copyright owner.

GENERAL TOLERANCES
 (Unless otherwise noted)
 0-100mm: ± 0.25 mm
 100mm - 500mm: ± 0.5 mm
 500mm +: ± 1.0 mm
 Angular: ± 1 deg.

Third Angle Projection
 - AS 1100

DATE: 3/30/2022

SCALE: D.N.S A3

All Dimensions are in Millimetres
 Break All Sharp Corners and
 Remove Burrs & Swarf

25
 Denotes Critical Dimension

PROJECT:

ITEM NO.

H2G-14

NOTES:

ITEM DESCRIPTION

HOSE2GO 14LTR

MATERIAL

SEE PARTS

FINISH

SEE PARTS

DRN: RT

MASS

REV

006

SHEET 1 OF 2

PRINTED: 3/30/2022

PRINT MAY BE REDUCED - DO NOT SCALE.

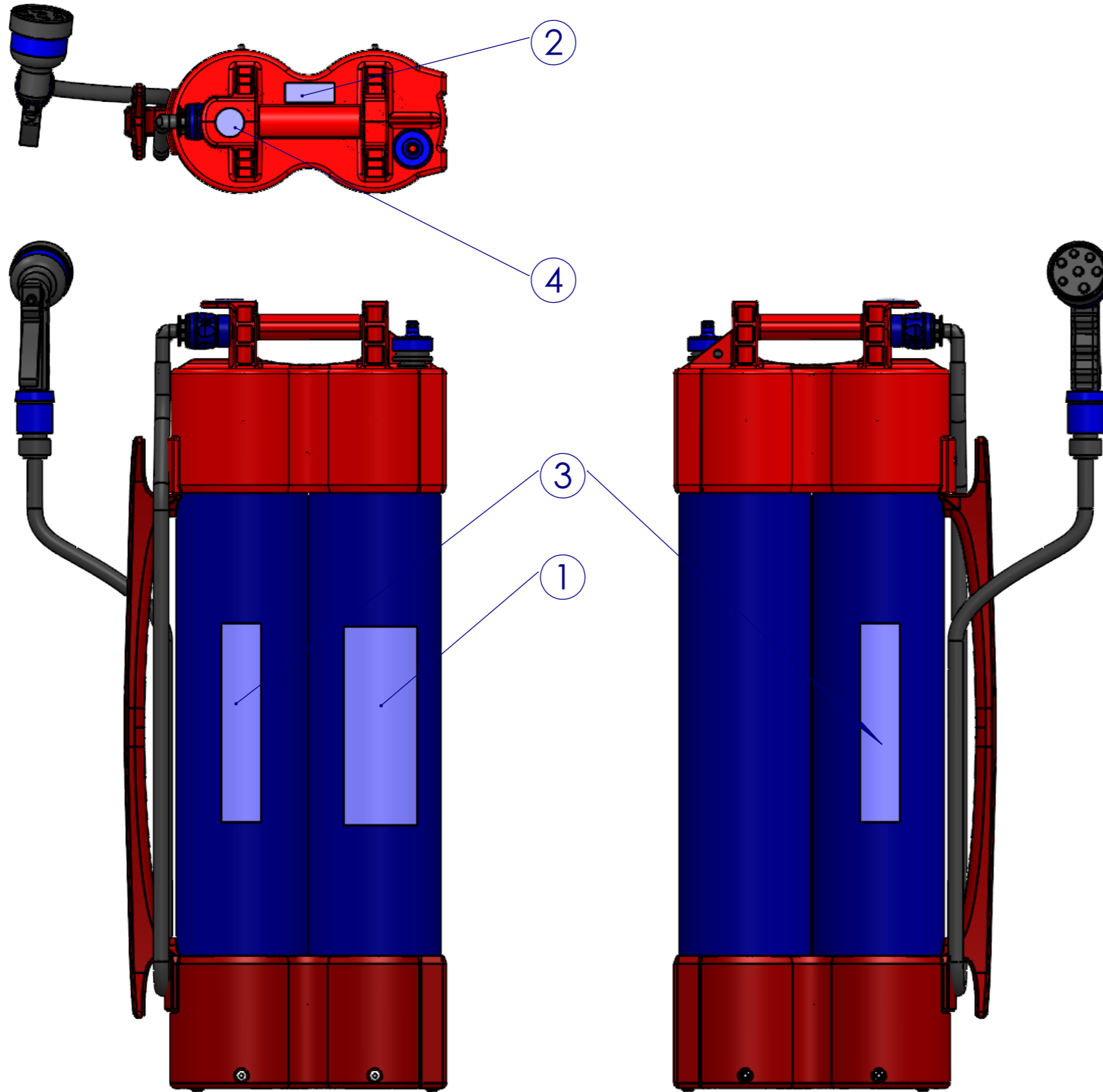

ITEM NO.	PART NO.	PART NAME	QTY
-	H2G-10-00	DECAL SET	1
1	H2G-10-01	STICKER-INSTRUCTION	1
2	H2G-10-02	STICKER-NON POTABLE WATER	1
3	MAK-UP-12	STICKER- MAKINEX LARGE	2
4	MAK-UP-14	STICKER- MAKINEX-X ROUND	1



Sydney (Head Office) Ph: 1300 795 953
 15 Waltham St Fax: (02) 9439 9815
 Artarmon, 2064 www.makinex.com.au
 NSW, Australia sales@makinex.com.au

COPYRIGHT 2015 MAKINEX.
 WARNING: Copyright in this drawing remains the property of MAKINEX and copying in whole or part is not permitted without the written authority of the copyright owner.

GENERAL TOLERANCES
 (Unless otherwise noted)
 0-100mm: ± 0.25 mm
 100mm - 500mm: ± 0.5 mm
 500mm +: ± 1.0 mm
 Angular: ± 1 deg.

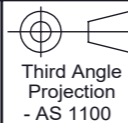

DATE: 3/30/2022

SCALE: D.N.S A3

All Dimensions are in Millimetres
 Break All Sharp Corners and
 Remove Burrs & Swarf



PROJECT:

ITEM NO.

H2G-14

NOTES:

ITEM DESCRIPTION

HOSE2GO 14LTR

MATERIAL

SEE PARTS

FINISH

SEE PARTS

DRN: RT

MASS

REV

006

SHEET 2 OF 2

PRINTED: 3/30/2022